



# Greenheck Roof Curbs

Technical Product Information

**CURB O.D. 38-1/2" x 38-1/2"**

P.O. NUMBER \_\_\_\_\_

CUSTOMER \_\_\_\_\_

PROJECT \_\_\_\_\_

LOCATION \_\_\_\_\_

ARCHITECT \_\_\_\_\_

## STANDARD CONSTRUCTION

- 18 GAUGE GALVANIZED STEEL
- 1-1/2", 3LB. DENSITY FIBERGLASS INSULATION
- WOOD NAILER FLUSH
- UNITIZED CONSTRUCTION
- CONTINUOUS WELDED CORNER SEAMS

## FITS

- |              |                |              |
|--------------|----------------|--------------|
| • GB 260     | • H-CUBE 300   | • TAUD 30    |
| • GB 300     | • H-CUBE 300HP | • TAUB-CA 30 |
| • GB 300HP   | • H-CUBE 300XP | • TAUB 30    |
| • H-GB 260   | • S-CUBE 300   | • ERD 24     |
| • H-GB 300   | • TCBRU 22     | • ESRMD 24   |
| • H-GB 300HP | • TCBRS 22     | • ESRMDF 24  |
| • LB 30      | • RSF 150      | • GRS 30     |
| • LBP 30     | • RSFP 150     | • GRSI 30    |
| • CUBE 300   | • SAF 118      | • GRSR 30    |
| • CUBE 300HP | • RDU 30       | • 32x32 WIH  |
| • CUBE 300XP | • RBU 30       | • 32x32 WRH  |

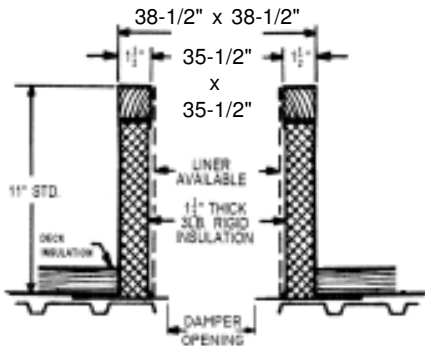

**RC-2A**

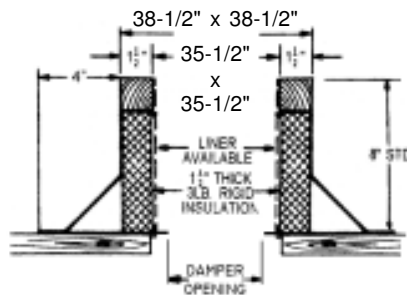

**RC-3A**

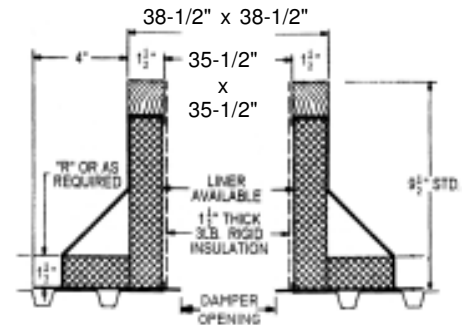

**RC-4A**

## PROJECT REQUIREMENTS

QTY.	STYLE	* OVERALL HEIGHT	"R" DIM.	PITCH REQUIREMENTS		DAMPER OPENING	TAG
				LONG SIDE	SHORT SIDE		