



Greenheck Roof Curbs

Technical Product Information

CURB O.D. 24-1/2" x 24-1/2"

P.O. NUMBER _____

CUSTOMER _____

PROJECT _____

LOCATION _____

ARCHITECT _____

STANDARD CONSTRUCTION

- 18 GAUGE GALVANIZED STEEL
- 1-1/2", 3LB. DENSITY FIBERGLASS INSULATION
- WOOD NAILER FLUSH
- UNITIZED CONSTRUCTION
- CONTINUOUS WELDED CORNER SEAMS

FITS

- G 150
- H-G 150
- LB 14
- NYD 140
- NYB 140
- USGF 140
- USGF 140HP
- USGF 160
- USGF 160HP
- USGF 160XP
- RSF 90
- RSFP 90
- AE 16
- AS 16
- TAUD 18
- TAUB-CA 18
- 18x18 FHI
- 18x18 FHR
- GRS 16
- GRSI 16
- GRSR 16
- 18x18 WIH
- 18x18 WRH

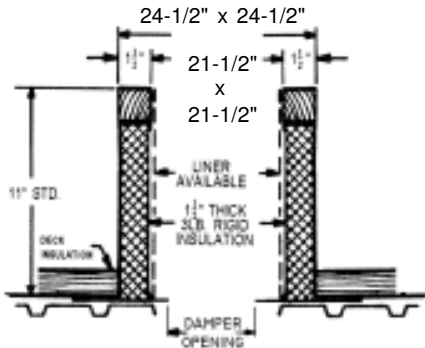

RC-2A

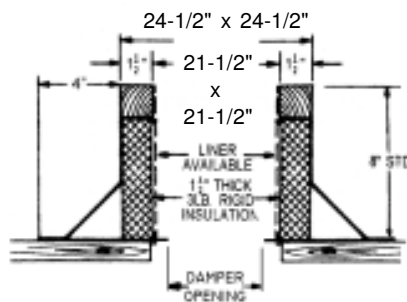

RC-3A

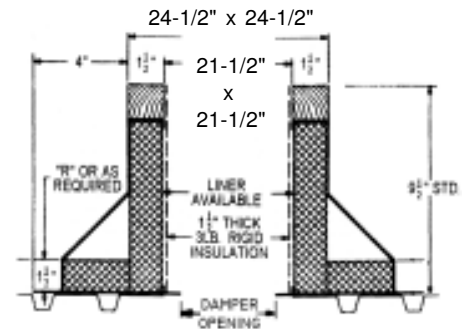

RC-4A

PROJECT REQUIREMENTS

QTY.	STYLE	* OVERALL HEIGHT	"R" DIM.	PITCH REQUIREMENTS		DAMPER OPENING	TAG
				LONG SIDE	SHORT SIDE		