



Loren Cook Roof Curbs

Technical Product Information

CURB O.D. 52-1/2" x 52-1/2"

P.O. NUMBER _____

CUSTOMER _____

PROJECT _____

LOCATION _____

ARCHITECT _____

STANDARD CONSTRUCTION

- 18 GAUGE GALVANIZED STEEL
- 1-1/2", 3LB. DENSITY FIBERGLASS INSULATION
- WOOD NAILER FLUSH
- UNITIZED CONSTRUCTION
- CONTINUOUS WELDED CORNER SEAMS

FITS

- | | | | | |
|-------------|---------------|-----------|------------|-----------|
| • 445 C | • 300 QMXE | • 42 ETS | • 42 HER | • 42 EUB |
| • 490 C | • 300 QMXS | • 42 HXEL | • 42 HEE-D | • 42 SUB |
| • 445 R | • 300 QMXE-HP | • 42 HXEM | • 42 HES-D | • 42 SUBH |
| • 490 R | • 300 QMXS-HP | • 42 HXSL | • 42 HEF-D | • 42 PR |
| • 445 V | • 300 QMXU | • 42 HXSM | • 42 HER-D | • 42 TR |
| • 490 V | • 300 QMXU-HP | • 42 HXFL | • 42 LXUL | • 42 LSUG |
| • 445 TLC-B | • 42 AQD | • 42 HXFM | • 42 LXUM | • 42 TUB |
| • 490 TLC-B | • 42 AQB | • 42 HEE | • 42 LEU | • 42 TUD |
| • 445 HLC-B | • 42 SEP | • 42 HES | • 42 AUD | • 42 LTU |
| • 490 HLC-B | • 42 ETE | • 42 HEF | • 42 AUB | |

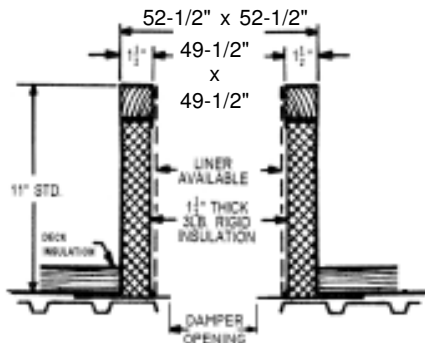

RC-2A

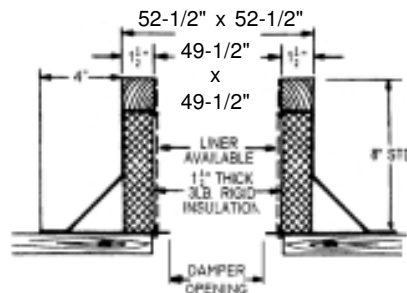

RC-3A

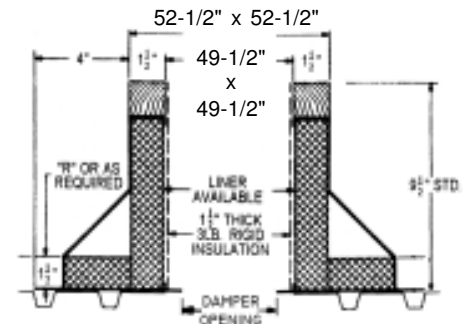

RC-4A

PROJECT REQUIREMENTS

QTY.	STYLE	* OVERALL HEIGHT	"R" DIM.	PITCH REQUIREMENTS		DAMPER OPENING	TAG
				LONG SIDE	SHORT SIDE		