



Loren Cook Roof Curbs

Technical Product Information

CURB O.D. 18-1/2" x 18-1/2"

P.O. NUMBER _____

CUSTOMER _____

PROJECT _____

LOCATION _____

ARCHITECT _____

STANDARD CONSTRUCTION

- 18 GAUGE GALVANIZED STEEL
- 1-1/2", 3LB. DENSITY FIBERGLASS INSULATION
- WOOD NAILER FLUSH
- UNITIZED CONSTRUCTION
- CONTINUOUS WELDED CORNER SEAMS

FITS

- | | | | |
|------------|--------------|----------------|--------------|
| • 120 C | • 120 SRSH-D | • 120 HLC-D | • 90 QMXS |
| • 135 C | • 120 SRSH-B | • 120 HLC-B | • 90 QMXE-HP |
| • 120 R | • 135 SRSH-D | • 135 HLC-D | • 90 QMXS-HP |
| • 135 R | • 135 SRSH-B | • 135 HLC-B | • 90 QMXU |
| • 120 SC | • 120 TLC-D | • 100 LPD | • 90 QMXU-HP |
| • 135 SC | • 120 TLC-B | • 100 LPB | • 12 UCV |
| • 120 V | • 135 TLC-D | • 620-740 PR12 | • 12 CVR |
| • 135 V | • 135 TLC-B | • 90 QMXE | • 12 CVR-S |
| • 12 REBEL | • 12 AQD | • 12 PR | • 12 TR |

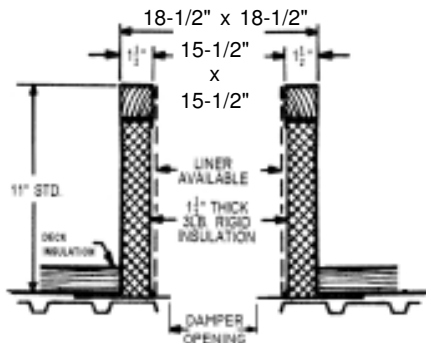

RC-2A

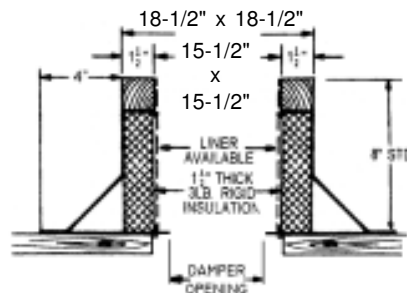

RC-3A

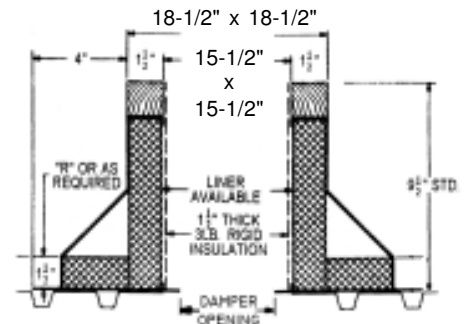

RC-4A

PROJECT REQUIREMENTS

QTY.	STYLE	* OVERALL HEIGHT	"R" DIM.	PITCH REQUIREMENTS		DAMPER OPENING	TAG
				LONG SIDE	SHORT SIDE		