



Loren Cook Roof Curbs

Technical Product Information

CURB O.D. 16-1/2" x 16-1/2"

P.O. NUMBER _____

CUSTOMER _____

PROJECT _____

LOCATION _____

ARCHITECT _____

STANDARD CONSTRUCTION

- 18 GAUGE GALVANIZED STEEL
- 1-1/2", 3LB. DENSITY FIBERGLASS INSULATION
- WOOD NAILER FLUSH
- UNITIZED CONSTRUCTION
- CONTINUOUS WELDED CORNER SEAMS

FITS

- | | | | |
|---------|-------------|--------------|---------------|
| • 60 C | • 100 SC | • 80 SRSH-D | • 100 TLC-B |
| • 70 C | • 100 V | • 80 SRSH-B | • 70 HLC-D |
| • 80 C | • 60 SRSH-D | • 85 SRSH-D | • 90 HLC-D |
| • 90 C | • 60 SRSH-B | • 100 SRSH-D | • 100 HLC-D |
| • 100 C | • 65 SRSH-D | • 100 SRSH-B | • 100 HLC-B |
| • 70 R | • 70 SRSH-D | • 70 TLC-D | • 122-520 PR8 |
| • 90 R | • 70 SRSH-B | • 90 TLC-D | • 8 PR |
| • 100 R | • 75 SRSH-D | • 100 TLC-D | • 8 TR |

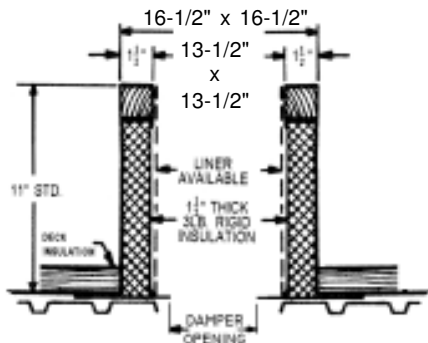

RC-2A

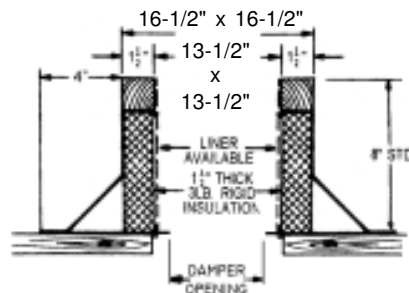

RC-3A

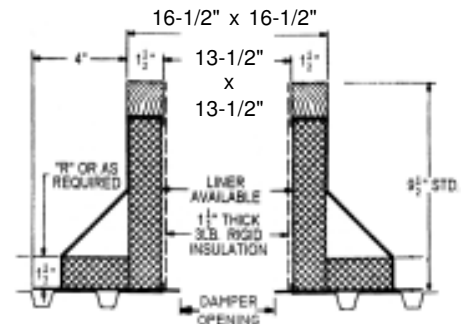

RC-4A

PROJECT REQUIREMENTS

QTY.	STYLE	* OVERALL HEIGHT	"R" DIM.	PITCH REQUIREMENTS		DAMPER OPENING	TAG
				LONG SIDE	SHORT SIDE		