



Expansion & Wall Curbs

Technical Product Information

EC-3A & EC-3B Styles

P.O. NUMBER _____

CUSTOMER _____

PROJECT _____

LOCATION _____

ARCHITECT _____

STANDARD CONSTRUCTION

- 18 GAUGE GALVANIZED STEEL
- 1-1/2", 3LB. DENSITY FIBERGLASS INSULATION
- WOOD NAILER
 - "A" STYLE FLUSH
 - "B" STYLE _____ OVERHANG
- UNITIZED CONSTRUCTION
- INTERNALLY REINFORCED

NOTE: STANDARD LUMBER OVERHANG 1/2" UNLESS SPECIFIED OTHERWISE

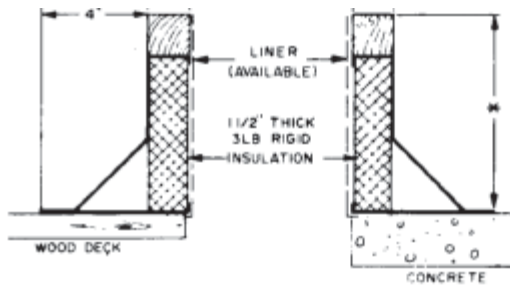

EC-3A STYLE

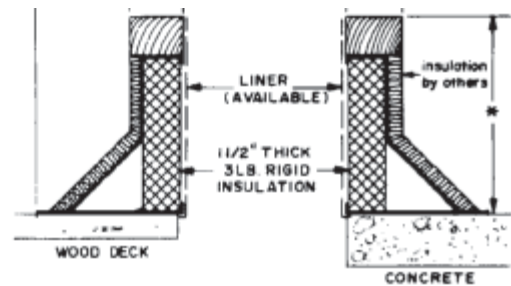

EC-3B STYLE

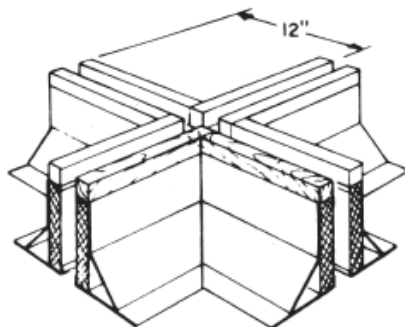

INTERSECTING JOINT
(Inside Corner (4 req'd))

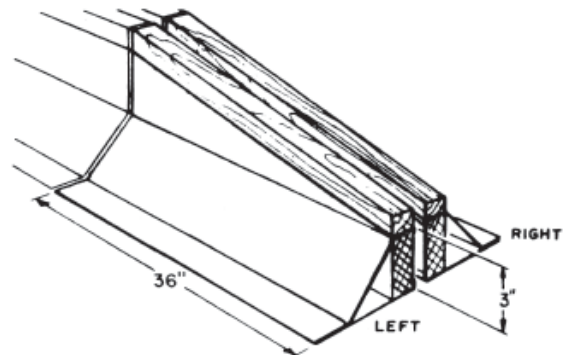

SLOPING END SECTION
(Left & Right Sections available)

* NOTE: STANDARD OVERALL HEIGHT 8" UNLESS SPECIFICALLY SHOWN BELOW

PROJECT REQUIREMENTS							
QTY.	STYLE	LENGTH	* OVERALL HEIGHT	"B" STYLE NAILER OVERHANG	PITCH REQUIREMENTS		TAG
					PITCH	RUN	