



# Carnes Roof Curbs

Technical Product Information

**CURB O.D. 22-1/2" x 54-1/2"**

P.O. NUMBER \_\_\_\_\_

CUSTOMER \_\_\_\_\_

PROJECT \_\_\_\_\_

LOCATION \_\_\_\_\_

ARCHITECT \_\_\_\_\_

### STANDARD CONSTRUCTION

- 18 GAUGE GALVANIZED STEEL
- 1-1/2", 3LB. DENSITY FIBERGLASS INSULATION
- WOOD NAILER FLUSH
- UNITIZED CONSTRUCTION
- CONTINUOUS WELDED CORNER SEAMS

### FITS

- 16 x 48 GI
- 16 x 48 GE
- 16 x 48 GL

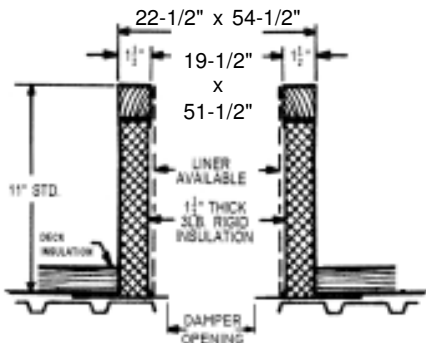

**RC-2A**

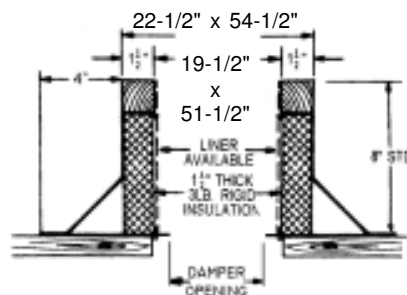

**RC-3A**

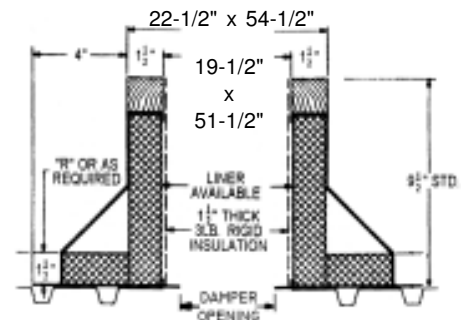

**RC-4A**

### PROJECT REQUIREMENTS

| QTY. | STYLE | * OVERALL HEIGHT | "R" DIM. | PITCH REQUIREMENTS |            | DAMPER OPENING | TAG |
|------|-------|------------------|----------|--------------------|------------|----------------|-----|
|      |       |                  |          | LONG SIDE          | SHORT SIDE |                |     |
|      |       |                  |          |                    |            |                |     |